

FEEDING

ROTOVALVE LIGHT

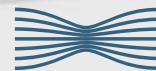

STERIVALVES
Process Advantage

Rotovalve Light is part of the modular system (see Modular System sheet). This valve is designed to feed and continuously control the discharged flow. Thanks to rotary alternating motion, it helps the product to be discharged homogeneously.

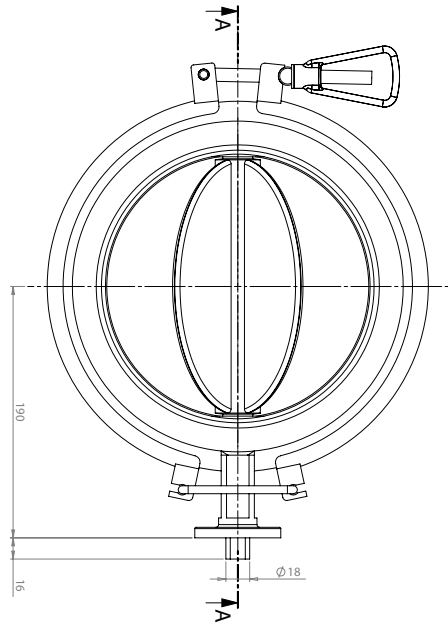
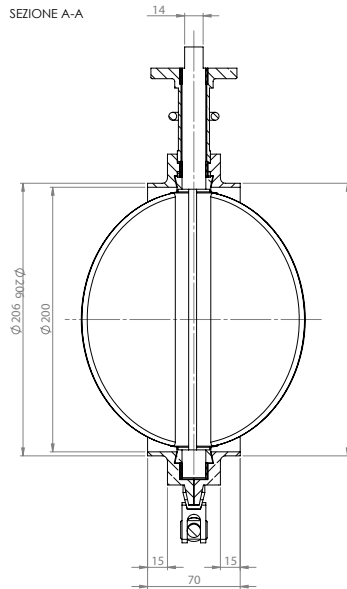

A possible configuration

TYPICAL APPLICATIONS:

Feeding of hoppers, packaging machines such as tablet presses in the pharmaceutical field
Feeding of homogenizers in the food and chemical/cosmetic field

MAIN FEATURES:

- Manufactured according to cGMP and EHEDG guidelines
- Suitable for CIP and SIP

MATERIALS:

- Body and rotor:
Stainless steel EN 1.4404 (AISI 316L)
- Seals:
Translucent Silicone, EPDM, FKM (Viton®), PTFE

MOTION DRIVE:

- Pneumatic actuator

DECLARATIONS AND CERTIFICATIONS:

- FDA Certification (CFR § 177.2600)
- Material Certificate 3.1 as per EN10204
- ATEX

SIZES:

80	100	150	200	250	300	350	400
----	-----	-----	-----	-----	-----	-----	-----

FINISH:

Ra 0.5 μ m internal, 1.2 μ m external